

■ SD-Road Lights





RL-1511

Road lights luminaire made in modern design for today fully adjustable to deliver light precisely where it is needed Main applications for Motorways, Major roads, minor roads, roundabouts, crossings and industrial areas.

For metal halide lamps or high pressure sodium for Max.150W G12 lamp holders. Die cast aluminium body coated with polyester in grey color.

Reflector made of highly pure aluminium sheet, polished and anodized.

Please contact our sales office for further details.

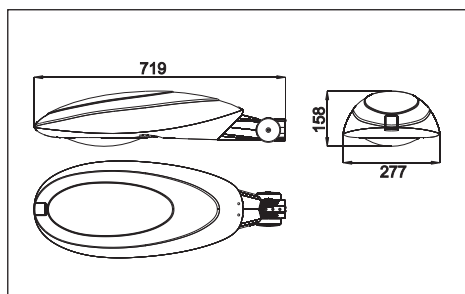



RL-1511

Lamp: MH 70/150W G12 / CPO-T 140W PGZ12

Reflector: Asymmetry Width

IP65      

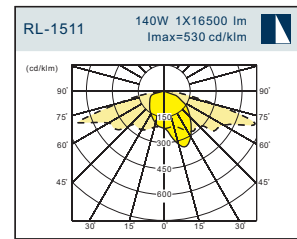

 PLA





Space

Road lights luminaire made in modern design for today fully adjustable to deliver light precisely where it is needed Main applications for Motorways, Major roads, minor roads, roundabouts, crossings and industrial areas.

For metal halide lamps or high pressure sodium for Max.400W E40 lamp holders. Die cast aluminium body coated with polyester in grey color.

Reflector made of highly pure aluminium sheet, polished and anodized.

Please contact our sales office for further details.



RL-1411

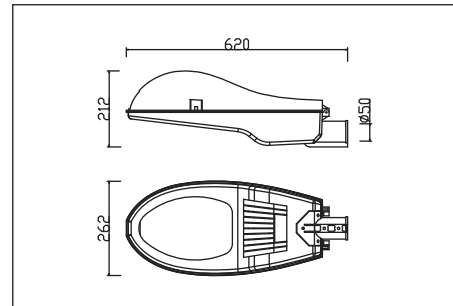

RL-1421

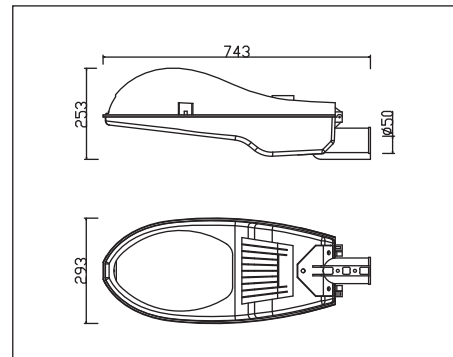



RL-1411

Lamp: MH 250W E40 / CPO-T 140W PGZ12

Reflector: Asymmetry Width

IP65       

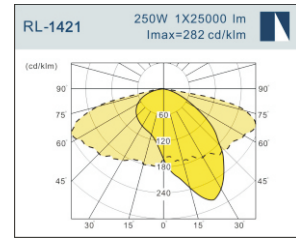

FL-1421

Lamp: MH 400W E40

Reflector: Asymmetry Width

IP65      

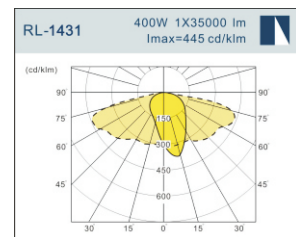



RL-1211

Road lights luminaire made in modern design for today fully adjustable to deliver light precisely where it is needed Main applications for Motorways, Major roads, minor roads, roundabouts, crossings and industrial areas.

For LED lamps 144x1W.

Die cast aluminium body coated with polyester in grey color.

Please contact our sales office for further details.

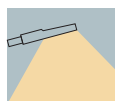

RL-1211

Lamp: LED 144 X 1W

Reflector: Asymmetry Width

IP65

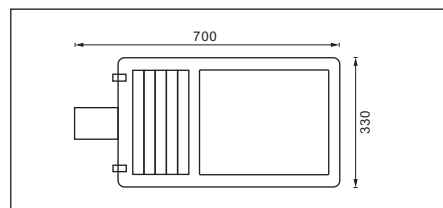
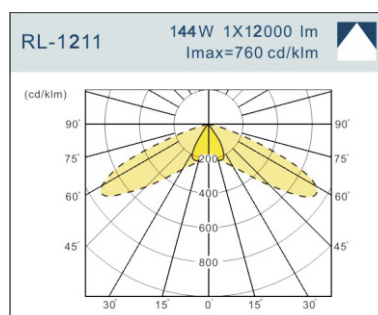



RL-1311

Road lights luminaire made in modern design for today fully adjustable to deliver light precisely where it is needed Main applications for Motorways, Major roads, minor roads, roundabouts, crossings and industrial areas.

For LED lamps 144x1.25W.

Die cast aluminium body coated with polyester in grey color.

Please contact our sales office for further details.

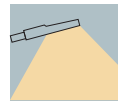

RL-1311

Lamp: LED 144 x 1.25W

Reflector: Asymmetry Width

IP65     

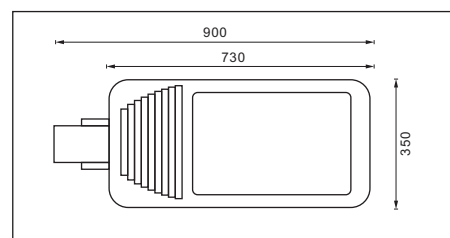
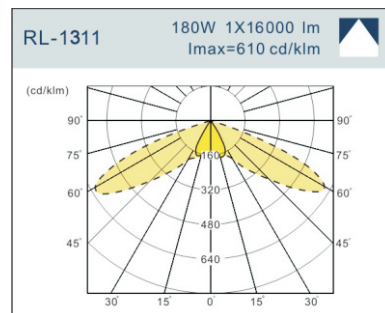
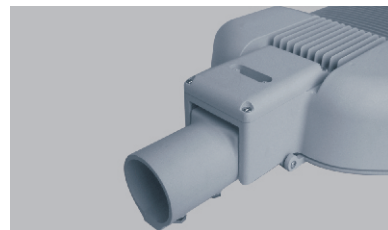



RL-1611

Road lights luminaire made in modern design for today fully adjustable to deliver light precisely where it is needed Main applications for Motorways, Major roads, minor roads, roundabouts, crossings and industrial areas.

For metal halide lamps or high pressure sodium for Max.400W E40 lamp holders. Die cast aluminium body coated with polyester in grey color.

Reflector made of highly pure aluminium sheet, polished and anodized.

Please contact our sales office for further details.

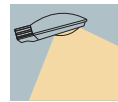

RL-1611

Lamp: MH 250W/400W E40
 Reflector: Asymmetry Width
 IP65

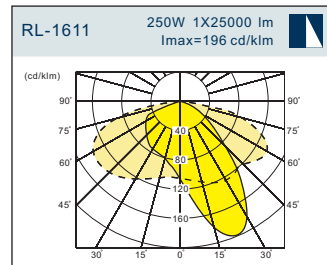

PLA

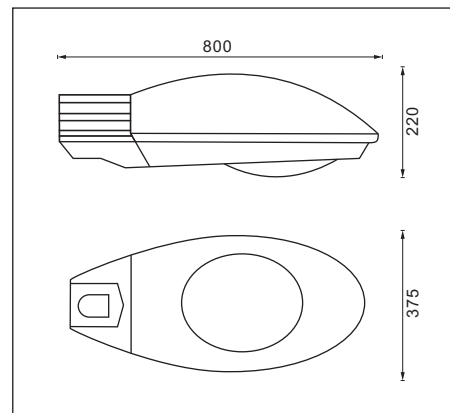



RL-1711

Road lights luminaire made in modern design for today fully adjustable to deliver light precisely where it is needed Main applications for Motorways, Major roads, minor roads, roundabouts, crossings and industrial areas.

For metal halide lamps or high pressure sodium for Max.400W E40 lamp holders. Die cast aluminium body coated with polyester in grey color.

Reflector made of highly pure aluminium sheet, polished and anodized.

Please contact our sales office for further details.



RL-1711

Lamp: MH 250W/400W E40
 Reflector: Asymmetry Width
 IP65     

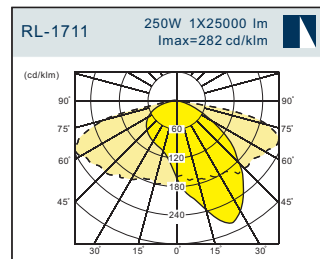

 PLA

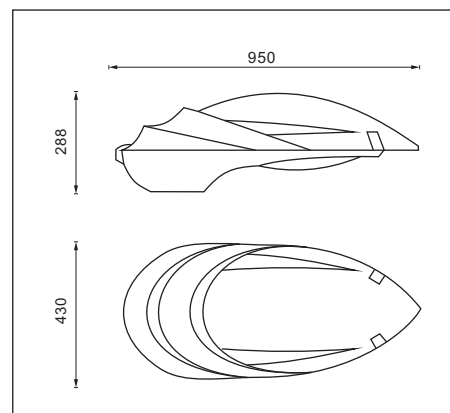



RL-1811

Road lights luminaire made in modern design for today fully adjustable to deliver light precisely where it is needed Main applications for Motorways, Major roads, minor roads, roundabouts, crossings and industrial areas.

For metal halide lamps or high pressure sodium for Max.400W E40 lamp holders. Die cast aluminium body coated with polyester in grey color.

Reflector made of highly pure aluminium sheet, polished and anodized.

Please contact our sales office for further details.



RL-1811

Lamp: MH 250W/400W E40
 Reflector: Asymmetry Width
 IP65

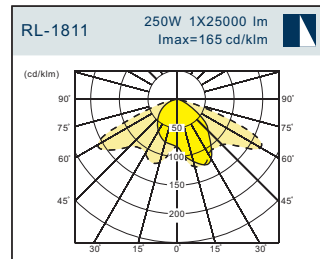

SAN

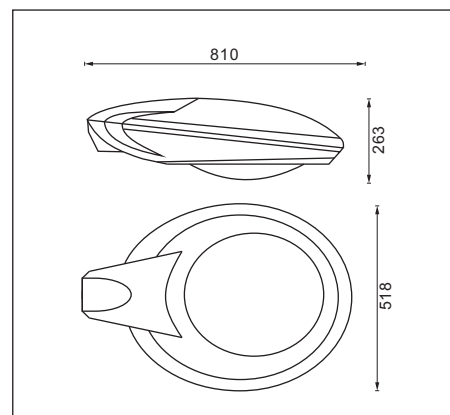



RL-1911

Road lights luminaire made in modern design for today fully adjustable to deliver light precisely where it is needed Main applications for Motorways, Major roads, minor roads, roundabouts, crossings and industrial areas.

For metal halide lamps or high pressure sodium for Max.400W E40 lamp holders. Die cast aluminium body coated with polyester in grey color.

Reflector made of highly pure aluminium sheet, polished and anodized.

Please contact our sales office for further details.



RL-1911

Lamp: MH 150W E27
 Reflector: Asymmetry Width
 IP65

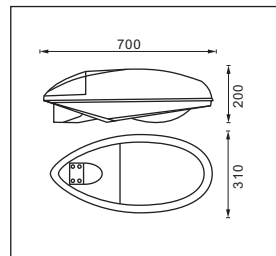

RL-1921

Lamp: MH 250W/400W E40
 Reflector: Asymmetry Width
 IP65

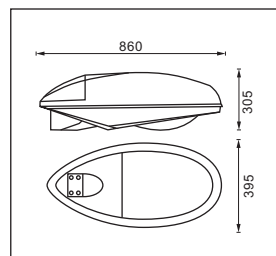



RL-2011

Road lights luminaire made in modern design for today fully adjustable to deliver light precisely where it is needed Main applications for Motorways, Major roads, minor roads, roundabouts, crossings and industrial areas.

For metal halide lamps or high pressure sodium for Max.400W E40 lamp holders. Die cast aluminium body coated with polyester in grey color.

Reflector made of highly pure aluminium sheet, polished and anodized.

Please contact our sales office for further details.

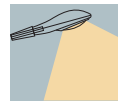

RL-2011

Lamp: MH 250W/400W E40
 Reflector: Asymmetry Width
 IP65

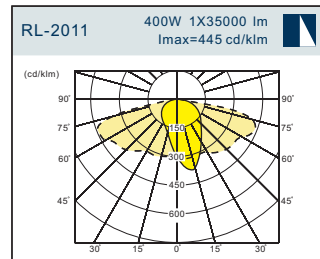

PLA

